

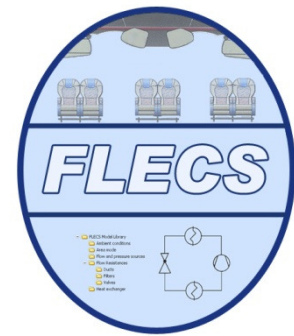

Hochschule für Angewandte
Wissenschaften Hamburg
Hamburg University of Applied Sciences



Aircraft Design and Systems Group (AERO)
Department of Automotive and Aeronautical Engineering
Hamburg University of Applied Sciences (HAW)
Berliner Tor 9
D - 20099 Hamburg

The Vapor Compression Cycle in Aircraft Air-Conditioning Systems

Christian Müller
Dieter Scholz

2017-01-04 (finalized)

Technical Note

Table of Contents

	page
1	Introduction 3
2	Inner Structure of a Vapor Compression Cycle..... 5
3	Validation of the Vapor Compression Cycle 8
4	Control Aspects of the Vapor Compression Machine..... 10
5	Dynamic Simulation of a VCM Air-Conditioning System 12
6	Comparison of an Air-Conditioning System Consisting of an ACM and a VCM Pack Model..... 17
7	Alternative VCM Configurations 21
	References 23

1 Introduction

The vapor compression cycle (VCC) is the principle of Vapor Compression Refrigeration Systems (VCRS) known in aviation as the Vapor Cycle Machines (VCM). Conventional air conditioning systems, heat pumps, and refrigeration systems that are able to cool (or heat, for heat pumps) and dehumidify air in a defined volume (e.g., a living space, an interior of a vehicle, a freezer, etc.) work on this principle.

The vapor compression cycle is made possible because the refrigerant is a fluid that exhibits specific properties when it is placed under varying pressures and temperatures. A typical vapor compression cycle system is a closed loop system and includes a compressor, a condenser, an expansion device and an evaporator. The various components are connected via a conduit (usually copper tubing). A refrigerant continuously circulates through the four components via the conduit and will change state, as defined by its properties such as temperature and pressure, while flowing through each of the four components.

The main operations of a vapor compression cycle are compression of the refrigerant by the compressor, heat rejection by the refrigerant in the condenser, throttling of the refrigerant in the expansion device, and heat absorption by the refrigerant in the evaporator. Refrigerant in the majority of heat exchangers is a two-phase vapor-liquid mixture at the required condensing and evaporating temperatures and pressures. Some common types of refrigerant include R22, R134a, and R410a. In following R134a is considered as refrigerant.

In the vapor compression cycle, the refrigerant nominally enters the compressor as a slightly superheated vapor (its temperature is greater than the saturated temperature at the local pressure) and is compressed to a higher pressure. The compressor includes a motor (usually an electric motor) and provides the energy to create a pressure difference between the suction line and the discharge line and to force the refrigerant to flow from the lower to the higher pressure. The pressure and temperature of the refrigerant increases during the compression step. The pressure of the refrigerant as it enters the compressor is referred to as the suction pressure and the pressure of the refrigerant as it leaves the compressor is referred to as the head or discharge pressure. The refrigerant leaves the compressor as highly superheated vapor and enters the condenser. A “typical” air-cooled condenser comprises single or parallel conduits formed into a serpentine-like shape so that a plurality of rows of conduit is formed parallel to each other. Although the present document makes reference to air-cooled condensers, the invention also applies to other types of condensers (for example, water-cooled).

Metal fins or other aids are usually attached to the outer surface of the serpentine-shaped conduit in order to increase the transfer of heat between the refrigerant passing through the condenser and the ambient air. A fan mounted proximate the condenser for pumping outdoor ambient air through the rows of conduit also increase the transfer of heat.

As refrigerant enters a condenser, the superheated vapor first becomes saturated vapor in the first section of the condenser, and the saturated vapor undergoes a phase change in the remainder of the condenser at approximately constant pressure. Heat is rejected from the refrigerant as it passes through the condenser and the refrigerant nominally exits the condenser as slightly sub-cooled liquid (its temperature is lower than the saturated temperature at the local pressure).

The expansion (or metering) device reduces the pressure of the liquid refrigerant thereby turning it into a saturated liquid-vapor mixture at a lower temperature, before the refrigerant enters the evaporator. This expansion is also referred as the throttling process. The expansion device is typically a capillary tube or fixed orifice in small capacity or low-cost air conditioning systems, and a thermal expansion valve (TXV or TEV) or electronic expansion valve (EXV) in larger units. The TXV has a temperature-sensing bulb on the suction line. It uses that temperature information along with the pressure of the refrigerant in the evaporator to modulate (open and close) the valve to try to maintain proper compressor inlet conditions. The temperature of the refrigerant drops below the temperature of the indoor ambient air as the refrigerant passes through the expansion device. The refrigerant enters the evaporator as a low quality saturated mixture (“Quality” is defined as the mass fraction of vapor x in the liquid-vapor mixture).

A direct expansion evaporator physically resembles the serpentine-shaped conduit of the condenser. Ideally, the refrigerant completely boils by absorbing energy from the defined volume to be cooled (e.g., the interior of a refrigerator). In order to absorb heat from this volume of air, the temperature of the refrigerant must be lower than that of the volume to be cooled. Nominally, the refrigerant leaves the evaporator as slightly superheated gas at the suction pressure of the compressor and reenters the compressor thereby completing the vapor compression cycle (It should be noted that the condenser and the evaporator are types of heat exchangers).

An air compressor driven by an electric motor is usually positioned in front of the evaporator; a separate fan/motor combination is also usually positioned next to the condenser. Inside the evaporator the heat transfer is from the compressed ambient air to the refrigerant flowing through the evaporator. For the condenser, the heat transfer is from the refrigerant flowing through the condenser to the ambient air.

2 Inner Structure of a Vapor Compression Cycle

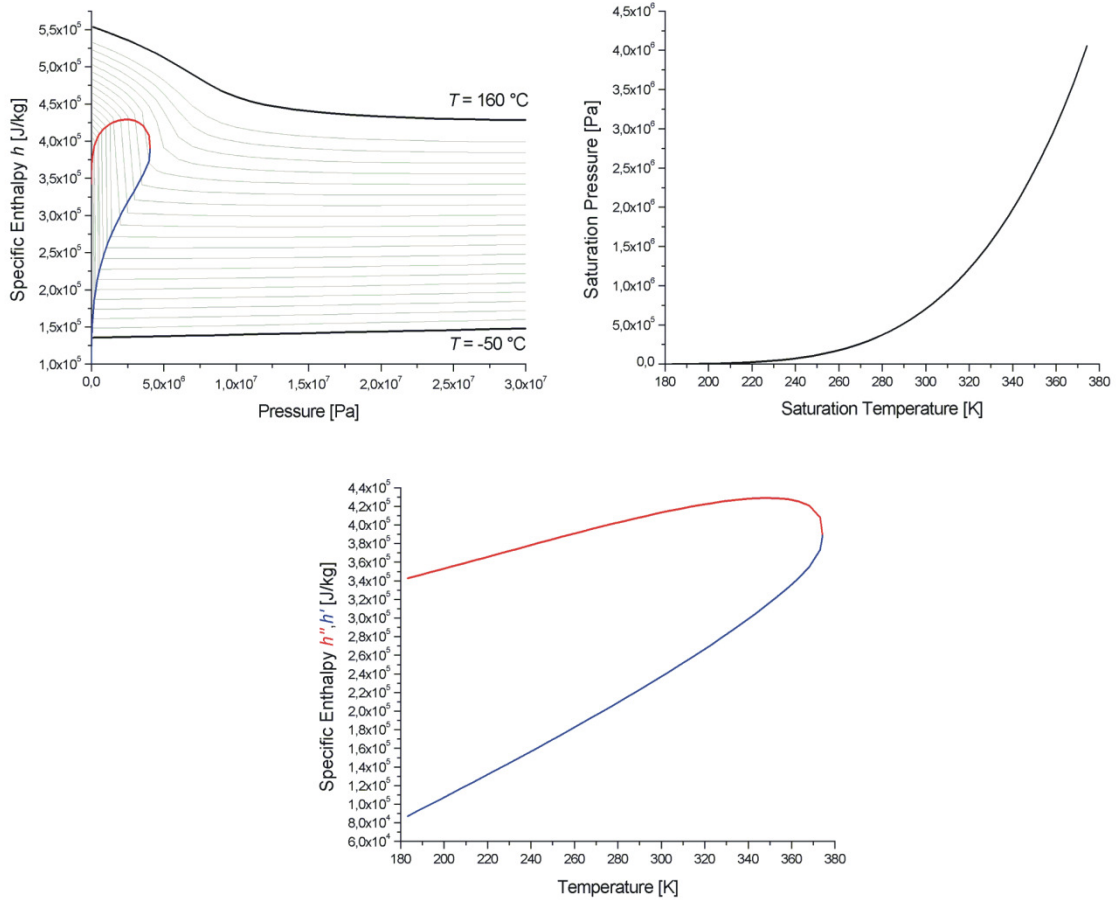

Figure 2.1: Characteristic maps of vapor compression cycle model

The algorithm of vapor compression cycle (VCC) is based on the characteristic maps shown in Figure 2.1. Using characteristic maps have the advantage, that the VCC model can be used easily for other refrigerants. The condenser R134a flow is cooled by a cold airflow ($\dot{m}_{cold,air}$, $T_{cold,air,inlet}$). Inside the Evaporator a hot airflow ($\dot{m}_{hot,air}$, $T_{hot,air,inlet}$) is cooled down to a target temperature $T_{hot,target}$.

1. Evaporator (see Figure 2.1):

Cooling:

$$\dot{Q}_{evap} = \dot{m}_{hot,air} c_{p,air} (T_{hot,air,inlet} - T_{hot,air,target})$$

Mass flow of the refrigerant:

$$\dot{m}_{R134a} = \frac{\dot{Q}_{evap}}{h_1 - h_4}$$

Saturation Temperature:

$$T_{evap,sat}(p_{evap}) = T_{hot,air,inlet} + \left(\frac{1}{\eta_{evap}}\right) (T_{hot,air,target} - T_{hot,air,inlet})$$

Outlet Parameter:

$$h_{evap,outlet} = h_1 = h''(p_{evap}) + \Delta h_{superheating}, \Delta h_{superheating} = \frac{(T_{cold,air,inlet} - T_{hot,air,target}) \dot{Q}_{evap}}{T_{hot,air,target}}$$

$$h_{evap,inlet} = h_4 = h'(p_{evap}) + x (h''(p_{evap}) - h'(p_{evap}))$$

$$T_{evap,outlet} = \frac{h_{evap,outlet}}{c_{p,R134a}}, c_{p,R134a} = \frac{h''(p_{evap})}{T_{evap,sat}}$$

2. Compressor (see Figure 2.1):

Isentropic Compression:

$$T_{comp,isentropic} = T_{evap} \left(\frac{p_{comp}}{p_{evap}} \right)^{\frac{\gamma_{R134a}-1}{\gamma_{R134a}}}, \gamma_{R134a} = 1.13$$

$$h_{comp,isentropic} = h(p_{comp}, T_{comp,isentropic})$$

Outlet Parameter:

$$h_{comp,outlet} = h_2 = h_{evap,outlet} + \frac{1}{\eta_{comp}} (h_{comp,isentropic} - h_{evap,outlet})$$

$$T_{comp,outlet} = \frac{h_{comp,outlet}}{c_{p,R134a}}, c_{p,R134a} = \frac{h_{comp,isentropic}}{T_{comp,isentropic}}$$

$$P_{comp} = \dot{m}_{R134a} (h_{comp,outlet} - h_{evap,outlet})$$

3. Condenser (see Figure 2.1):

Subcooling:

$$T_{cond,outlet} = T_{comp,outlet} + \eta_{cond} (T_{cold,air,inlet} - T_{comp,outlet})$$

$$\Delta T_{cond} = T_{cold,air,inlet} - T_{cond,outlet}$$

Outlet Parameter:

$$T_{cold,air,cond} = T_{cond,sat}(p_{comp}) - \Delta T_{cond}$$

$$h_{cond,outlet} = h_3 = h_4 = h''(p_{comp}) - \frac{\dot{m}_{cold,air}}{\dot{m}_{R134a}} c_{p,air} (T_{cold,air,cond} - T_{cold,air,inlet})$$

$$\dot{Q}_{cond} = \dot{m}_{R134a} (h_{comp,outlet} - h_{cond,outlet})$$

$$T_{cold,air,outlet} = T_{cold,air,inlet} + \frac{\dot{Q}_{cond}}{\dot{m}_{cold,air} c_{p,air}}$$

Derivation Enthalpy:

$$\frac{\Delta h}{h} = \Delta hh = \frac{h_{cond,outlet} - h_{evap,inlet}}{h_{evap,inlet}}$$

Derivation Cold Air Mass Flow:

$$\dot{m}_{cold,air,target} = \frac{\dot{m}_{R134a} (h''(p_{comp}) - h_{evap,inlet})}{c_{p,air} (T_{cold,air,cond} - T_{cold,air,inlet})}$$

$$\frac{\Delta \dot{m}}{\dot{m}} = \Delta \dot{m} \dot{m} = \frac{\dot{m}_{cold,air,target} - \dot{m}_{cold,air}}{\dot{m}_{cold,air}}$$

The specific outlet enthalpy $h_{cond,outlet}$ is calculated without knowledge of the calculated specific inlet enthalpy $h_{evap,inlet}$. In general both enthalpies aren't equal. Therefore the derivation Δhh can be used to adjust the cold airflow.

The discussed algorithm is a non-closed cycle and can be used as dynamic vapor cycle model with help of a set of different controllers (see section 4.4.3).

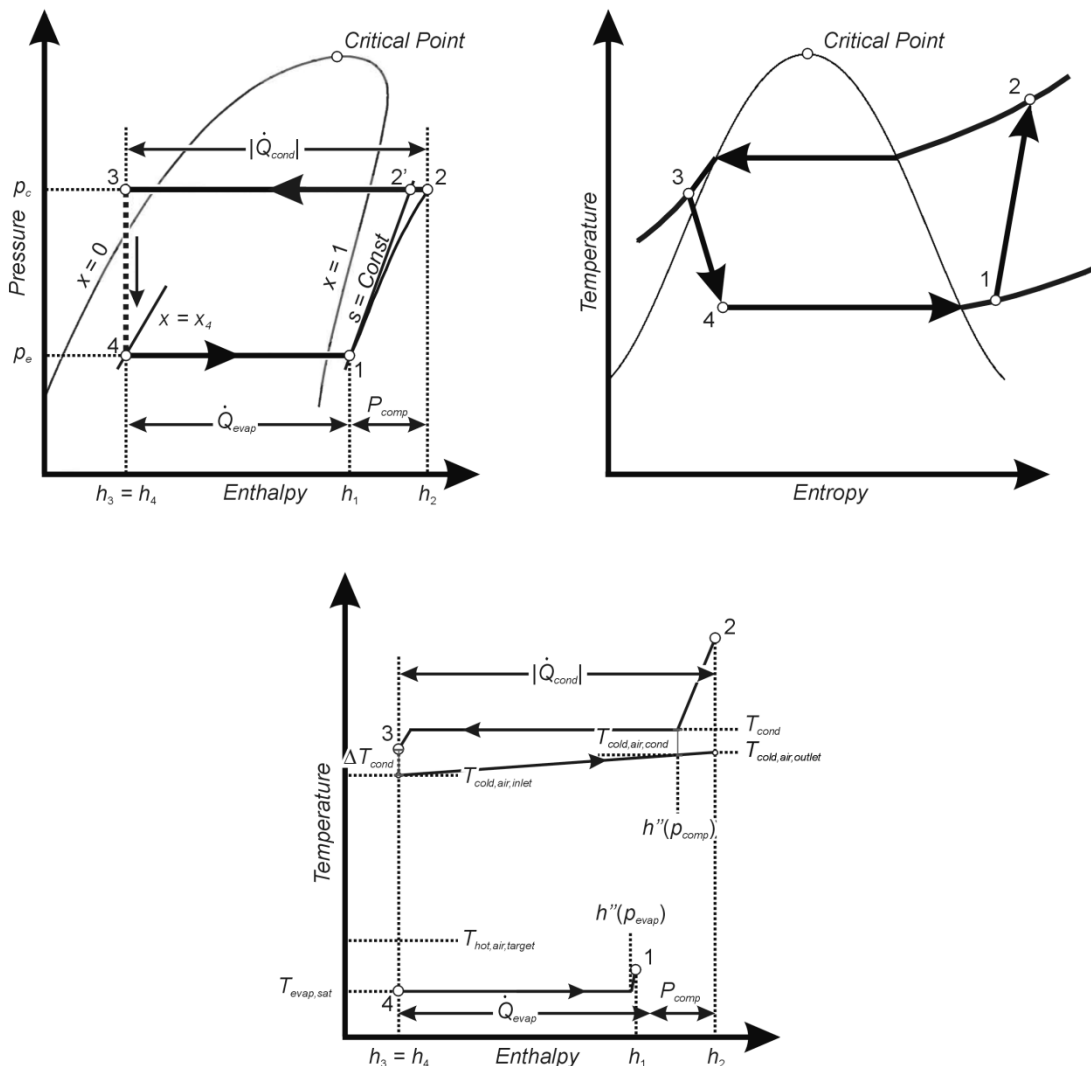

Figure 2.1: p - h , T - s respectively T - h diagrams of R134a refrigerant

3 Validation of the Vapor Compression Cycle

The VCC algorithm discussed above can be validated with help of an example given in [Baehr 2006] (see Table 3.1).

Table 3.1: Validation Example [Baehr 2006]

	p kPa	t °C	h kJ/kg	
1	115	-20,00	387,15	Cooling Capacity, Evaporator: 35000 W
2'	750	40,99	426,68	
2	750	52,06	437,82	Cooling Capacity R134a Flow, Condenser: 46510 W
3	750	24,00	233,13	
4	115	-23,37	233,13	Mass Flow R134a: 0.227 kg/s
				Power Consumption Compressor: 11514 W
				Mass Fraction of Vapor x : 0.3

The example shown in Table 13 is related with water cooling of the R134a Flow inside the evaporator and an ambient temperature $T_{ambient} = T_{cold,air,inlet}$ of 18 °C. Ensuring a sufficient cooling in the case of air cooling an airflow of $\dot{m}_{cold,air} = 8$ kg/s has to be assumed. The mass flow of the hot air is fixed to $\dot{m}_{hot,air} = 0.5$ kg/s

Table 3.2: Set of efficiencies

Efficiencies:	
Heat Transfer Efficiency Evaporator η_{evap} :	0.90
Isentropic Efficiency Compressor η_{comp} :	0.78
Heat Transfer Efficiency Condenser η_{cond} :	0.80

The algorithm can be validated using the set of efficiencies shown in Table 3.2. The results of the simulation are shown in Figure 3.1.

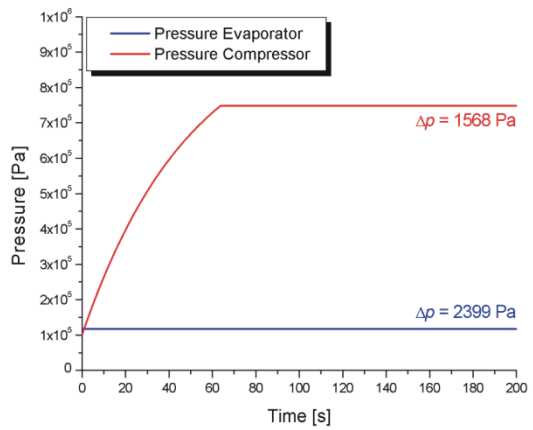
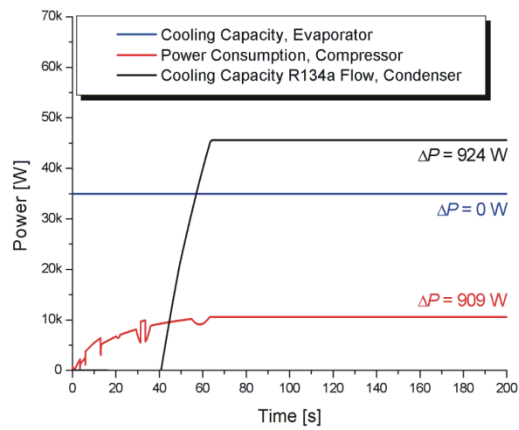
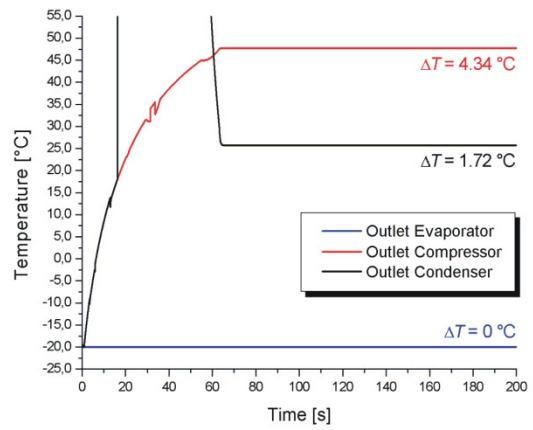
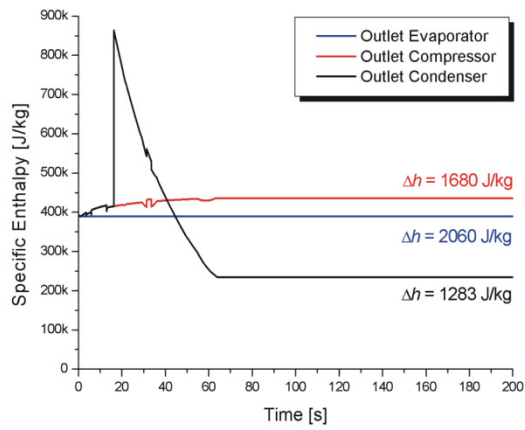

Figure 3.1: Validation of the VCC algorithm with help of an example given in [Baehr 2006]

4 Control Aspects of the Vapor Compression Machine

The general control structure of an aircraft ECS is shown in Figure 4.1.

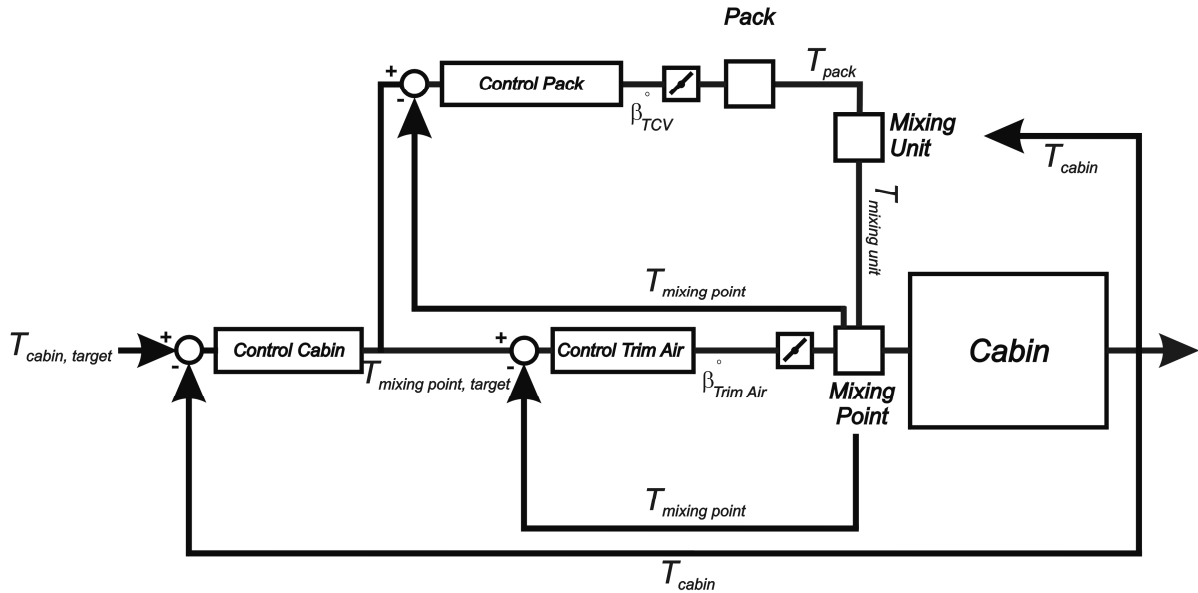

Figure 4.1: Control configuration of an environmental control system

Vapor Cycle Machine (VCM) Compressor Controller: This controller controls the compressor pressure p_{comp} ensuring a closed refrigerant loop ($\dot{Q}_{cond} = \dot{Q}_{evap} + P_{comp}$). The controller is characterized by a response time $\tau_{vcm,comp}$. The compressor controller is a part of the inner structure of the VCM model.

Using the VCM model as an aircraft air-conditioning pack additionally three other controllers have to be defined.

Ram Air Fan Rotational Speed Controller: This controller controls the rotational speed of the ram air fan. In general as higher the rotational speed as higher the ram air mass flow. The ram air mass flow and the ram air inlet temperature define the cooling capacity of the R134a flow inside the condenser. As actuating variable the value Δhh is used. The controller is characterized by a response time $\tau_{n,fan}$.

Flow Controller: This controller controls the volume flow of the hot bleed air to a target value \dot{V}_{target} . The control variable is the opening angle β_{FCV} of flow control valve (FCV). The higher the rotational speed the higher the ram air mass flow. The ram air mass flow and the ram air inlet temperature define the cooling capacity of the R134a flow inside the condenser. As actuating variable the value Δhh is used. The controller is characterized by a response time

τ_{FCV} . Knowing the volume flow \dot{V}_{target} the mass flow \dot{m}_{FCV} through the flow control valve can be calculated using Equation 8.

$$\dot{m}_{FCV} = V_{target} \frac{P_{cabin}}{287.057 T_0} \quad (1)$$

Air Compressor Rotational Speed Controller: This controller controls the rotational speed of the air compressor assuring a outlet pressure $p_{air,comp,outlet} \geq p_{cabin} + 27500$ Pa and a outlet temperature $T_{air,comp,outlet} \geq 50$ °C = 323.15 K. The controller is characterized by a response time $\tau_{air,comp}$.

of the different controllers are $\tau_{vcmb,comp} = \tau_{n,fan} = 20$ s and $\tau_{FCV} = \tau_{air,comp} = 5$ s. Three different test cases (1: ISA Cold Day, 2: ISA Standard Day, 3: ISA Hot Day) are discussed.

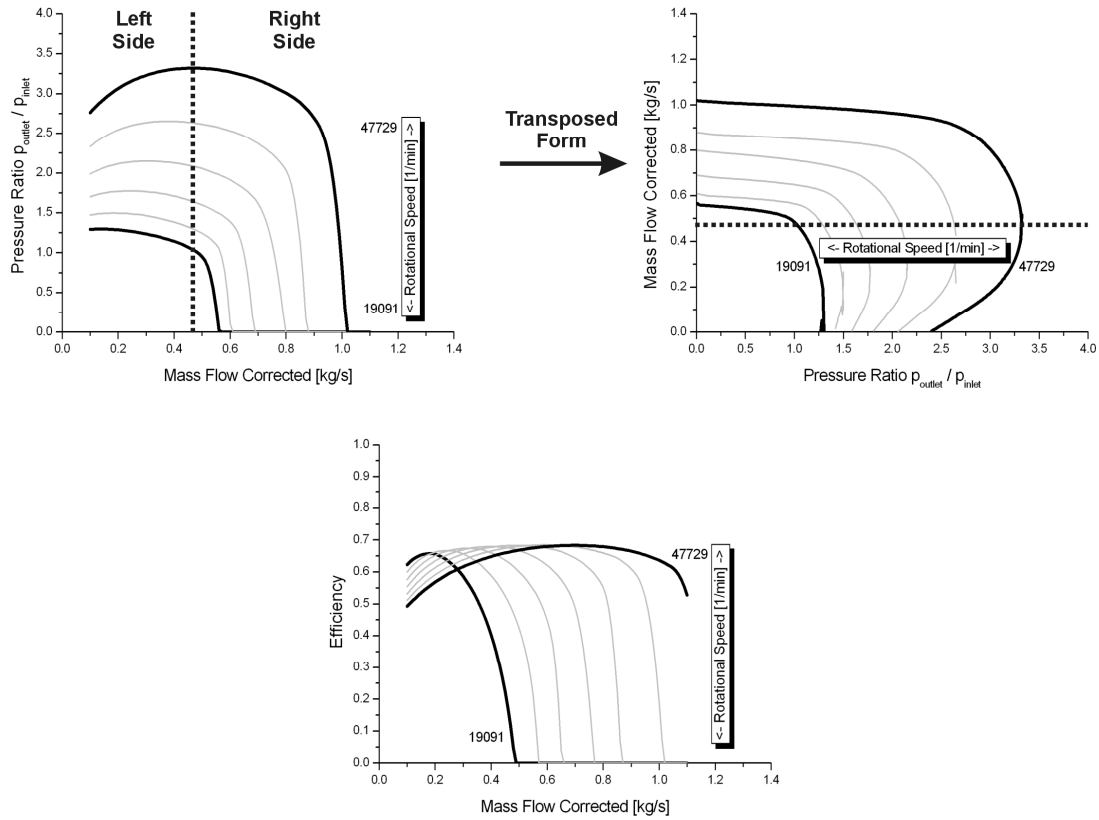

Figure 5.2: Characteristic maps of the air compressor

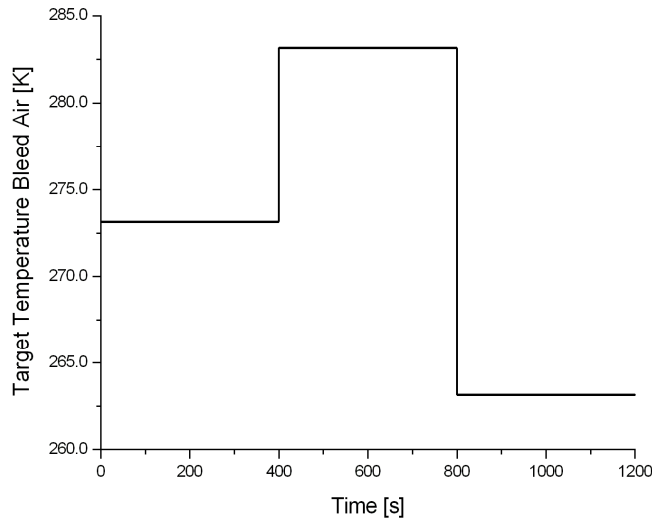

Figure 5.3: The target temperature of the bleed air

1. ISA Cold Day:

Ambient Pressure:	101300 Pa
Ambient Temperature:	250.15 K = -23 °C

2. ISA Standard Day:

Ambient Pressure:	101300 Pa
Ambient Temperature:	288.15 K = 15 °C

3. ISA Hot Day:

Ambient Pressure:	101300 Pa
Ambient Temperature:	311.15 K = 38 °C

Results:

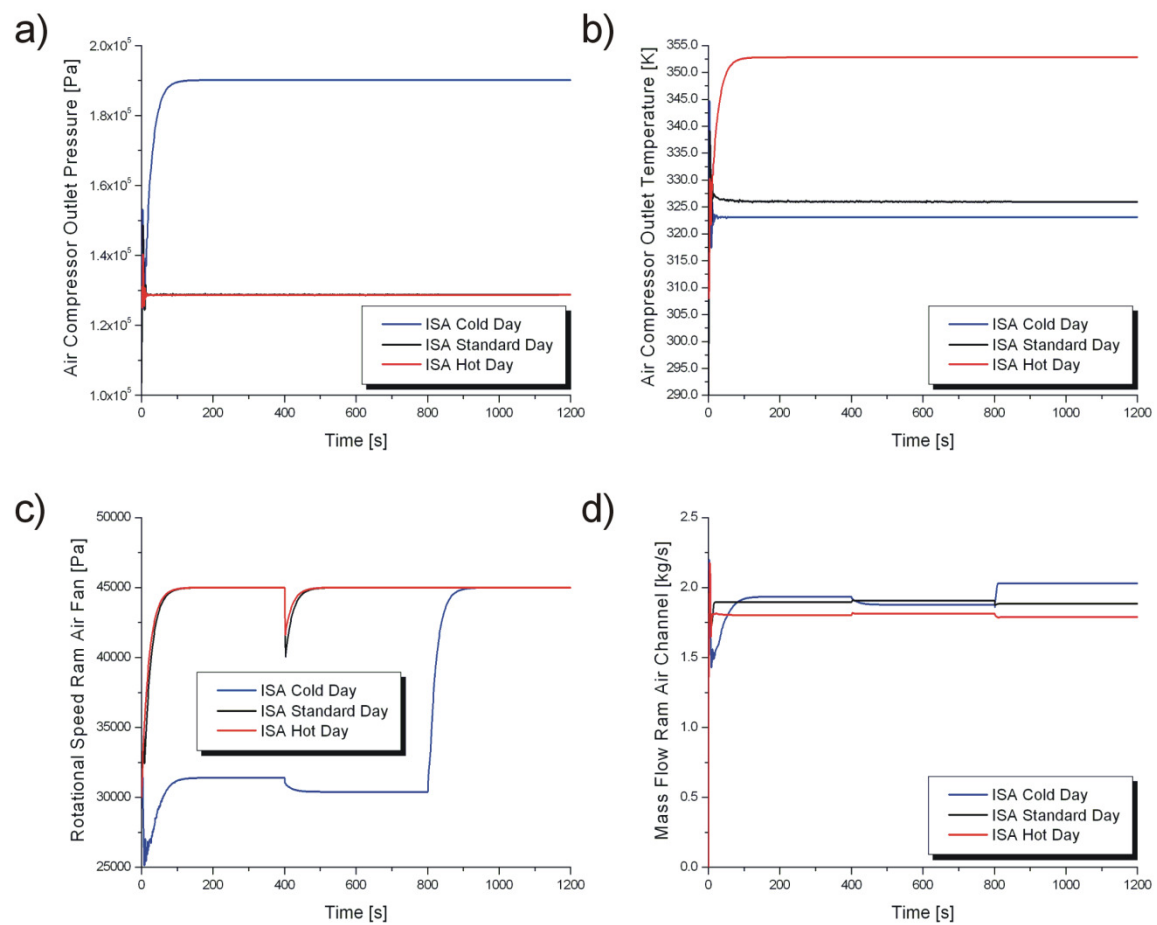

Figure 5.4: The dynamic behavior of the VCM air-conditioning system under different ambient conditions

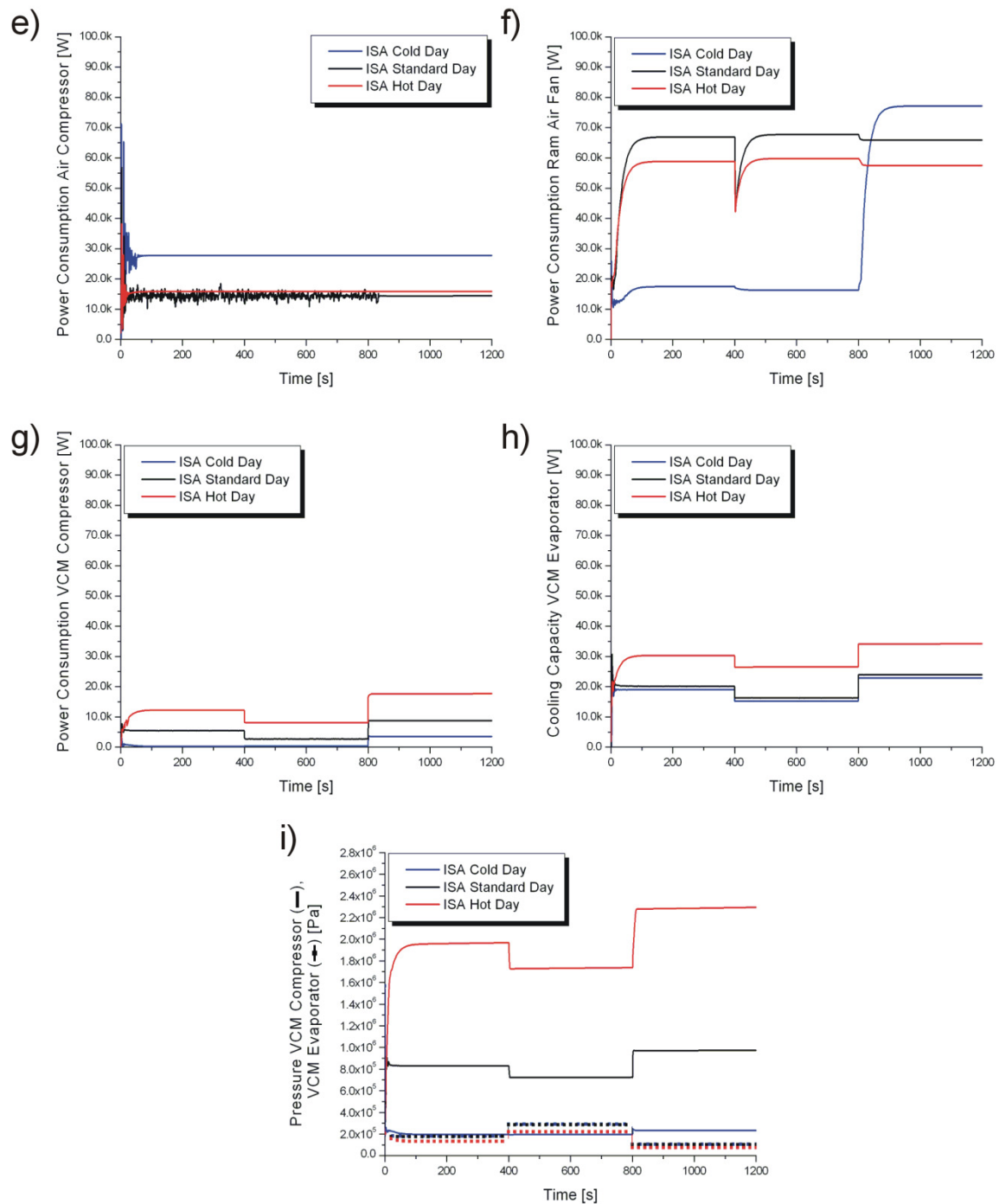

Figure 5.5: The dynamic behavior of the VCM air-conditioning system under different ambient conditions

Comments:

In the case, that the system is controlled to a pressure $p_{comp} < p_{evap}$, the VCM compressor power consumption P_{comp} is set to zero (see Figure 50g and Figure 50i, ISA Cold Day). The variable Δhh can be used to check if the refrigerant loop is closed. In the case ISA Cold Day and ISA Standard Day the relative derivation Δhh is smaller than 5 %, and therefore the loop is fully or almost closed. In the case ISA Hot Day Δhh is significant higher than 5 %. Therefore the loop is only partially closed. Under this ambient conditions a cascade refrigeration cycle should be used (see Figure 5.7)

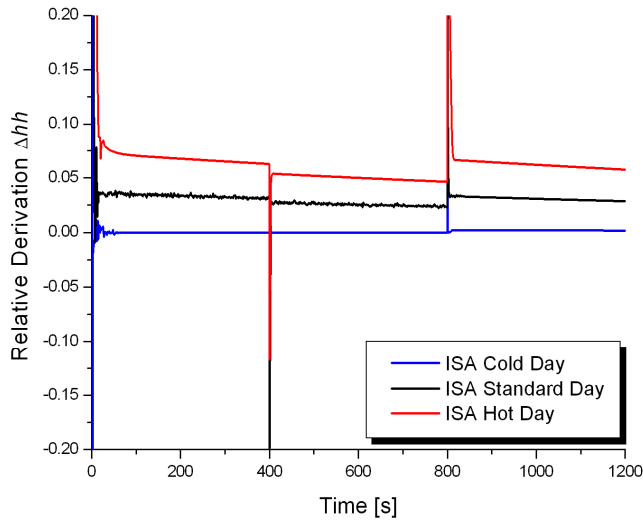

Figure 5.6: The relative derivation Δhh under different ambient conditions

This cycle will lead to a decrease in the temperature at the point 3, meaning increasing cooling capacity. Additionally this configuration will minimize the power consumption of the compressor. With this cycle, it is not an obligation to use the same refrigerant. If the refrigerants are different, the appropriate T - s diagram has to be used.

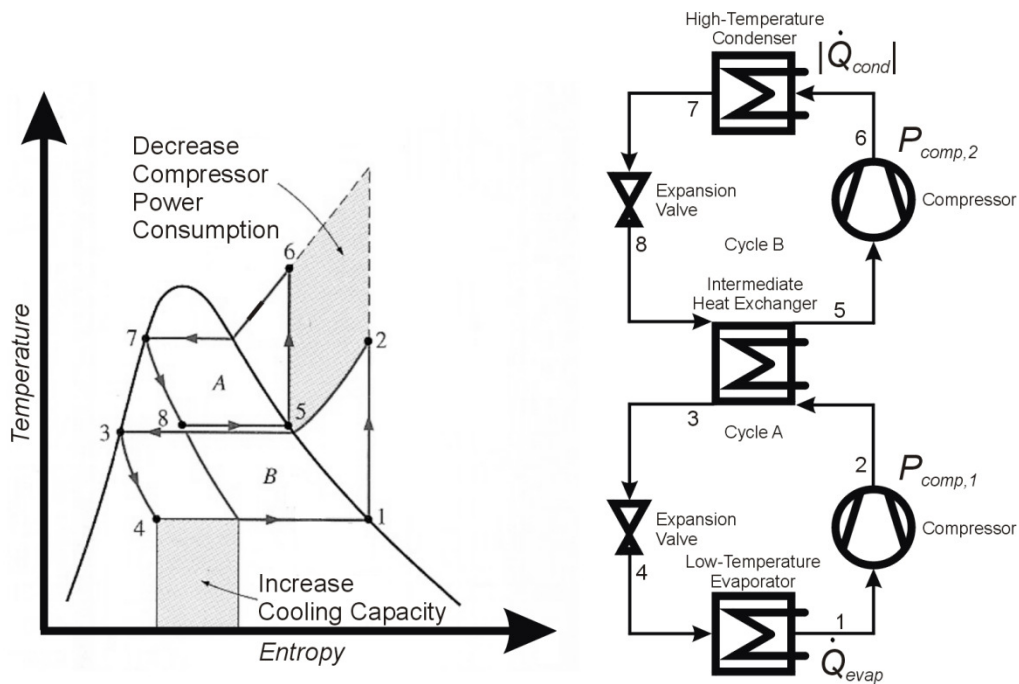

Figure 5.7: A cascade refrigeration cycle

6 Comparison of an Air-Conditioning System Consisting of an ACM and a VCM Pack Model

In this section the performance of a air-conditioning consisting of an ACM pack is compared with a system consisting of a VCM pack. The parameterization of the overall system e.g. the trim air system or the cabin model is already mentioned in Section 3.2 of Technical Note FLECS_WT3.2_5.1_5.2_5.3_TN (confidential) [Müller 2008].

The dimension of the ram air inlet is given in Table 12 of Müller 2008. Inside the VCM systems the area of the ram air inlet is fixed to the maximum value ($\zeta = 1$). The outlet temperature of the VCM model shows a steady state behavior (see Figure 5.4). The outlet temperature is an input value of the simulation and is fixed by the pack controller (see Figure 11 of Müller 2008). To compare both systems also the ACM pack model has to be defined in a steady state configuration. A steady state model can be described by mass flow source. The temperature is fixed by the pack controller. The mass flow can be calculated with help of Equation 1 ($\dot{V}_{target} = 0.34 \text{ m}^3/\text{s}$).

Inside the ECS system the rotational speed of the recirculation fan is fixed to 7500 1/min assuring a ratio $\dot{m}_{recirculation} / \dot{m}_{pack} = 1$. The floor temperature inside the cabin model is always 10 °C smaller than the average temperature of the cabin ($T_{floor} = 0.5 (T_{zone,1} + T_{zone,2}) - 10 \text{ °C}$).

Response time controller:

VCM System:

VCM Compressor Controller:	20 s
Ram Air Fan Rotational Speed Controller:	20 s
Flow Controller:	5 s
Air Compressor Rotational Speed Controller:	5 s

Global Parameter:

On ground:	ISA standard day ($T_{ambient} = 15 \text{ °C}$, $p_{ambient} = 101300 \text{ Pa}$)
In flight:	ISA conditions
Bleed air temperature:	200 °C = 473.15 K
Trim air pressure:	$p_{cabin} + 27500 \text{ Pa}$
Trim air temperature (ACM):	200 °C = 473.15 K
Trim air temperature (VCM):	$T_{air,comp,outlet}$

Aircraft Mission:**Time: 0 s ... 1200 s**

The aircraft is on ground. The boarding starts. The target temperature of the cabin is 21 °C. In 20 minutes 200 passengers enter the cabin (see Figure 5.5), assuming a constant flow of passengers. The heat load, which flows into the cabin, increases significantly.

Time: 1200 s ... 2250 s

1200 s: The boarding is completed. The aircraft starts. In 1050 s the aircraft climbs to a flight altitude of 35000 ft (climb rate 2000 ft/min) (see Figure 5.4). The ambient conditions are described by an ISA condition. Knowing the ambient temperature $T_{ambient}$ the skin temperature T_{skin} can be calculated ($T_{skin} = T_{ambient} (1 + 0.18 Ma^2)$, Ma: Mach number). The target temperature of the cabin zone 1 is 22 °C = 295.15 K, the target temperature of the cabin zone 2 is 24 °C = 297.15 K. The cabin pressure is fixed to 81224 Pa.

Time: 2250 s ... 5850 s

Cruise: The target temperature of the cabin zone 1 is 22 °C = 295.15 K, the target temperature of the cabin zone 2 is 24 °C = 297.15 K. The cabin pressure is fixed to 81224 Pa.

Time: 2250 s ... 6900 s

Descent: In 1050 s the aircraft with a rate of 2000 ft/min. The target temperature of the cabin zone 1 is 22 °C = 295.15 K, the target temperature of the cabin zone 2 is 24 °C = 297.15 K.

The profiles of the aircraft altitude, cabin pressure, Mach number and skin temperature are shown in Figure 5.4. In flight the minor loss coefficient of the ram air inlet is fixed to 1.5 (see Equation 6 of Müller 2008). The simulated temperature profiles in zone 1 and zone 2 are shown in Figure 5.4a. the trim air opening angle is shown in Figure 5.4b. The power consumption of the ACM system can be calculated using a enthalpy equation (see Equation 2 and Figure 5.4c).

$$P_{ACM} = \dot{m}_{pack} c_p (T_{bleed,air} - T_{pack,outlet}) \quad (2)$$

The overall power consumption of the VCM system is the sum of the power consumption of the ram air fan P_{fan} , the air compressor $P_{air,comp}$ and the VCM Compressor P_{comp} (see Equation 3 and Figure 5.4c).

$$P_{VCM} = P_{fan} + P_{air,comp} + P_{comp} \quad (3)$$

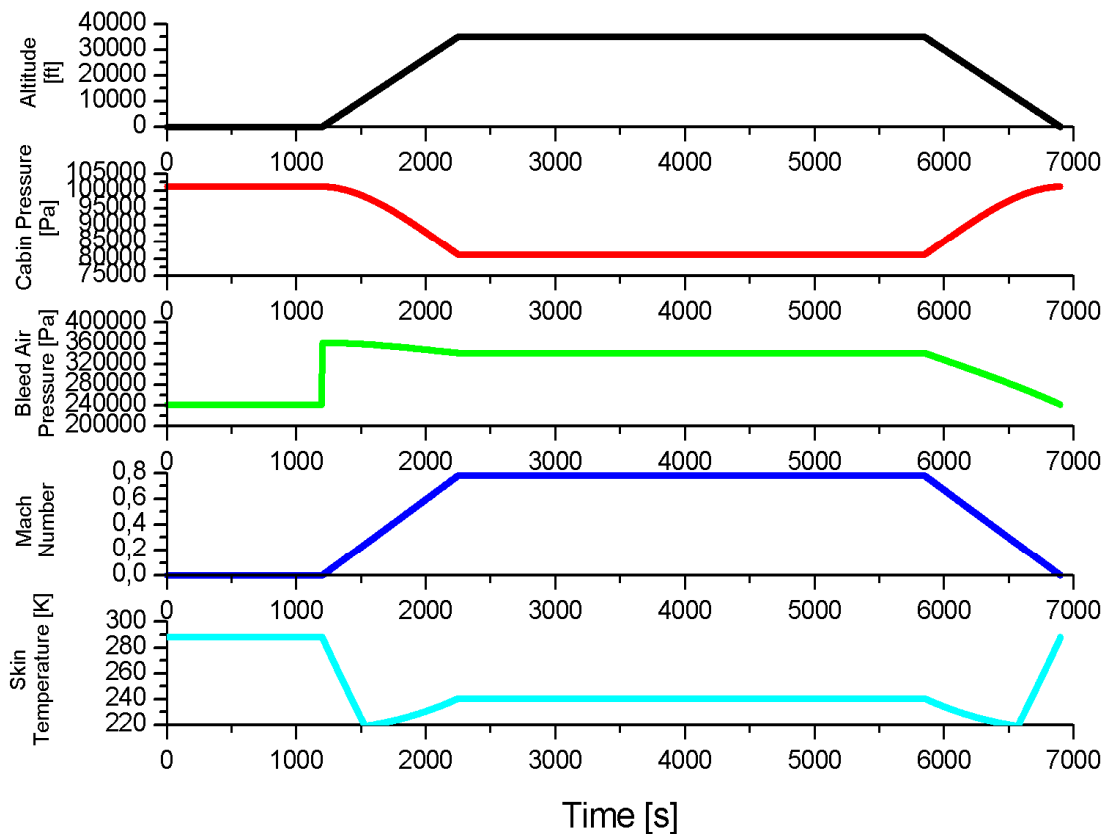

Figure 6.1: Time dependant ambient conditions

General benefits of the air cycle system are:

- low weight,
- low maintenance costs
- high reliability
- low costs
- problem-free with leakages
- heating and cooling capability
- delivery of sub-freezing air (enables to meet high dynamic cooling demands)
- air as medium ensures automatically environmental compatibility
- operation over wide temperature ranges

General benefits of the vapor cycle system are:

- high thermodynamic efficiency,
- low power input,
- more electric system can operate from ground electrical power,
- low noise level.

General ECS selection criteria are:

- An air cycle system is best at
 - o high required cabin mass flows,
 - o low power and bleed air penalties.
- A vapor cycle system is best at
 - o low required cabin mass flows,
 - o high power and bleed air penalties.

Quantitative results of fuel penalties due to selected ECS systems need to be calculated. Furthermore ECS systems can be compared based on Direct Operating Costs defined for aircraft systems (DOCsys) (**Scholz 1998**).

7 Alternative VCM Configurations

The standard VCM arrangement was already shown as Figure 5.1 and is repeated here as Figure 7.1 called Configuration 1. Alternative VCM Configurations 2, 3, and 4 are shown as Figure 7.2, Figure 7.3, and Figure 7.4.

Configuration 1:

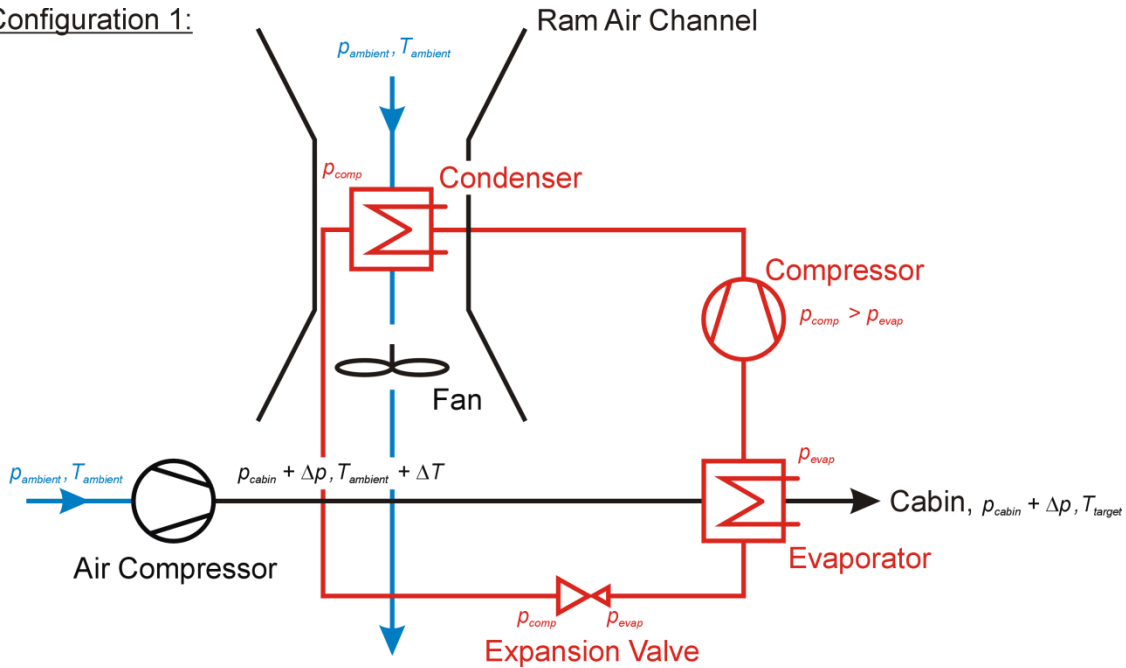

Figure 7.1: VCM integrated into an aircraft ECS in a standard way (Configuration 1)

Configuration 2:

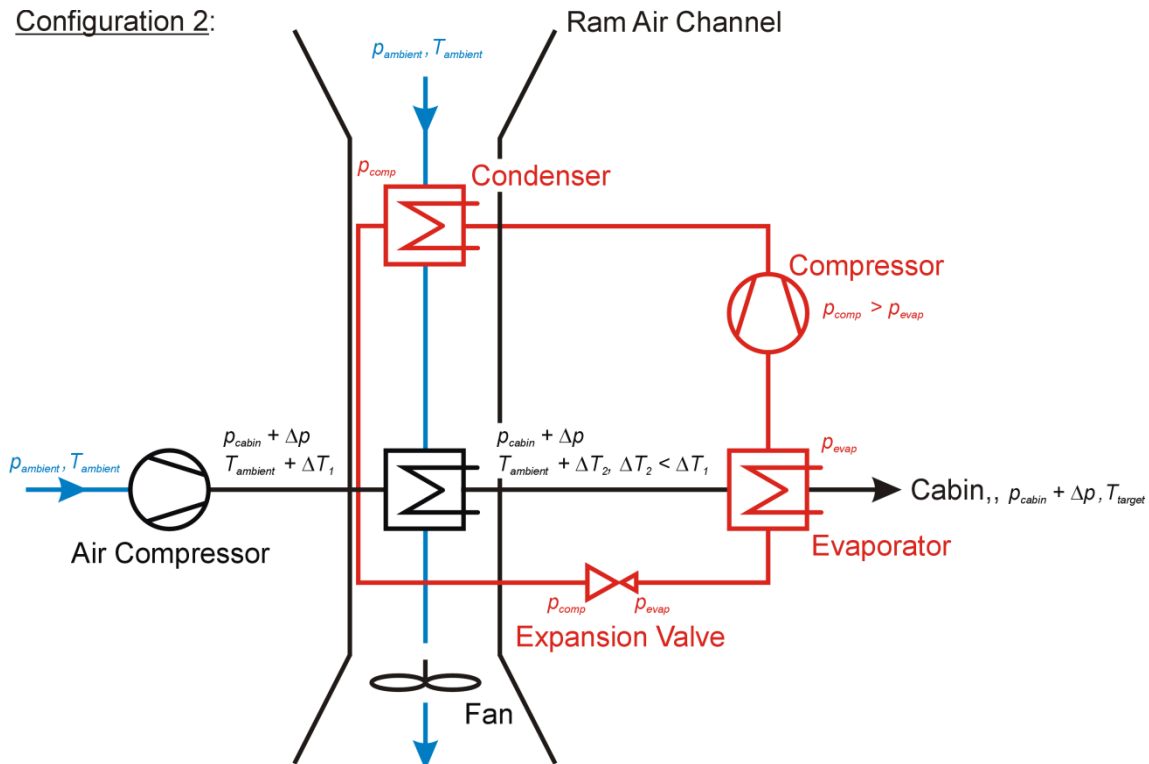

Figure 7.2: VCM integrated into an aircraft ECS in an alternative way (Configuration 2)

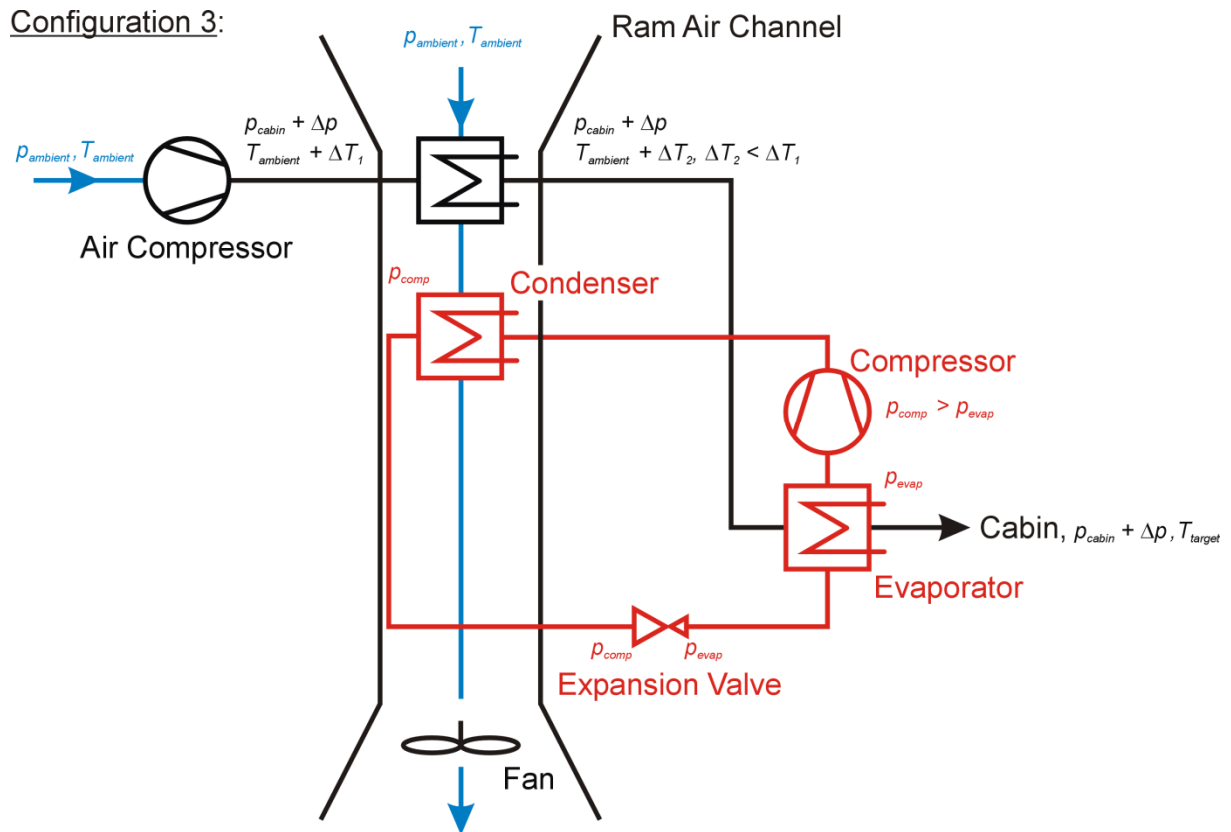

Figure 7.3: VCM integrated into an aircraft ECS in an alternative way (Configuration 3)

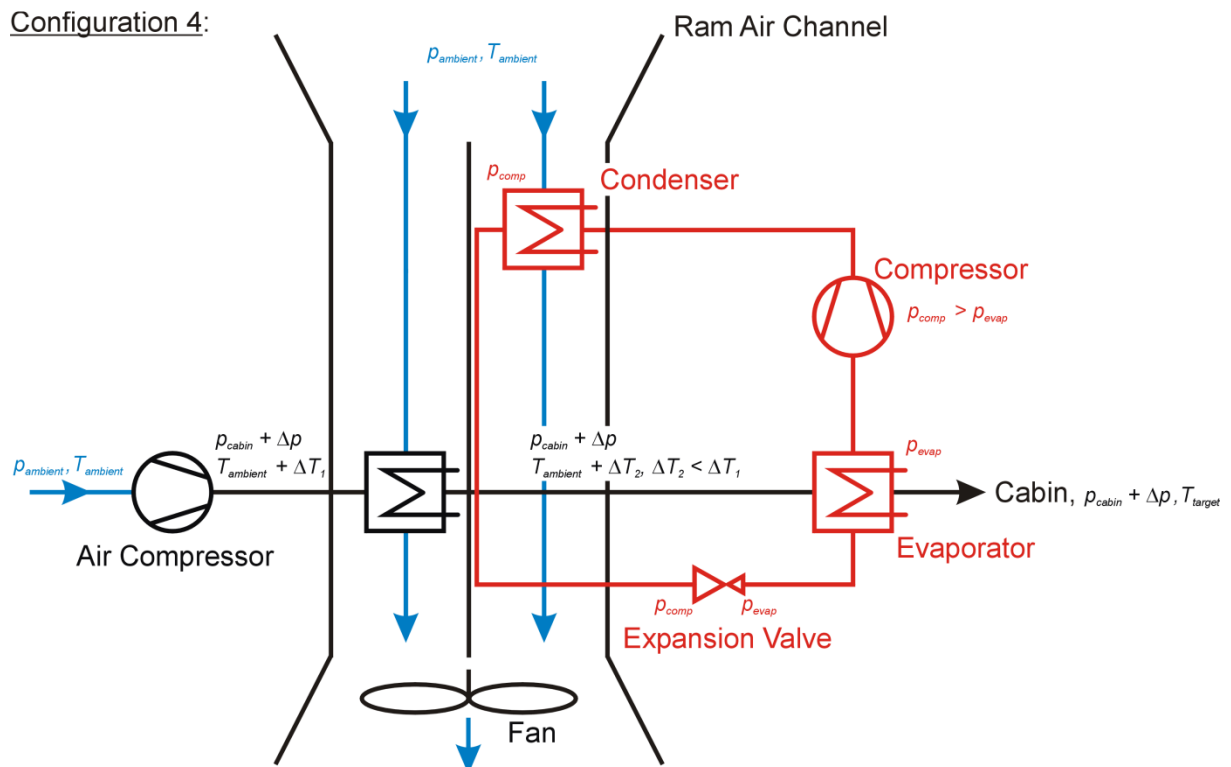

Figure 7.4: VCM integrated into an aircraft ECS in an alternative way (Configuration 4)

References

- Baehr 2006** BAEHR, Hans Dieter: *Thermodynamik*. Berlin : Springer. 2006
- Müller 2008** MÜLLER, Christian: *FLECS - Funktionale Modellbibliothek des Environmental Control Systems : Applications*. Technical Note. Aircraft Design and Systems Group (AERO), Department of Automotive and Aeronautical Engineering, Hamburg University of Applied Sciences (HAW), 1993. – DocumentID: FLECS_WT3.2_5.1_5.2_5.3_TN
- Scholz 1998** SCHOLZ, Dieter: DOCsys - A Method to Evaluate Aircraft Systems. In: SCHMITT, D. (Ed.): *Bewertung von Flugzeugen* (Workshop: DGLR Fachausschuß S2 - Luftfahrtsysteme, München, 26./27. Oktober 1998). Bonn : Deutsche Gesellschaft für Luft- und Raumfahrt, 1998. – Download from: <http://12.dglr.de>, <http://www.fzt.haw-hamburg.de/pers/Scholz/dglr/bericht1098/Bericht1098.html>, http://www.fzt.haw-hamburg.de/pers/Scholz/dglr/bericht1098/DGLR-1998_SCHOLZ_DOCsys_Eine_Methode_zur_Bewertung_von_Flugzeugsystemen.pdf